

# Get OnGas

Piped LPG supply



**FPb**

FUTURE-PROOF BUILDING



[www.ongas.co.nz](http://www.ongas.co.nz)

More and more people are discovering the joys and simplicity of living with gas. Why? Gas is a clean, convenient energy source. Whether it's for endless hot showers, cooking the perfect meal, heating your home or enhancing your outdoor lifestyle, OnGas is always ready when you are, for as long as you want it.

**Gas puts you in control** Whenever you want it, all it takes to command the power of gas is the flick of a switch or the press of a button.

**Gas is a healthy home solution.** A warm home is a healthy home and yet a third of New Zealand homes do not meet the World Health Organisation warmth standards of 18°C. Gas heating can provide instant, adjustable heat faster than electric appliances.

**Gas is economical** Gas is more efficient than many other energy fuels. Also, gas appliances are usually cheaper to operate and maintain in the long term.

**Gas is clean** Gas is the environmentally friendly fuel. Of all the fossil fuels available, gas creates the least greenhouse gas emissions and so contributes to the improvement of New Zealand's energy efficiency.

**Gas is safe** The built-in safety features of today's modern appliances and advances in technology ensure that gas is a safe energy option, whether piped or supplied in bottles. There are strict regulations governing the handling and storage of gas.

**Gas is here to stay** Gas remains plentiful in New Zealand, and is a long term energy source for heating our homes, cooking our dinners and providing endless hot water. Gas and LPG importation options are available to supplement local production if required.

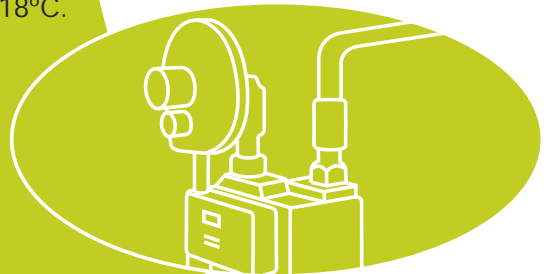

## Why home heating is easier with OnGas

Who wouldn't like a home that's snug and cosy even on the coldest winter nights? OnGas enables you to heat your home quickly and efficiently and in a way that's much kinder to the environment than many other forms of heating.

Fully programmable gas central heating systems give you complete control over the temperature of your home, and you never have to walk out of a warm room into a cold one. Gas heaters offer an affordable alternative in a wide range of colours and styles including modern flame effect fires as well as more traditional models. Flued heaters have an outlet to release combustion products into the outside air, and are recommended as the best solution for your main heating needs. Flueless heaters are also available for smaller rooms.

### Sizing the right heater for you

Follow this simple formula to calculate the best size heater for your room:

Let's say the room is 7 metres long x 5 metres wide x 2.4 metres high.

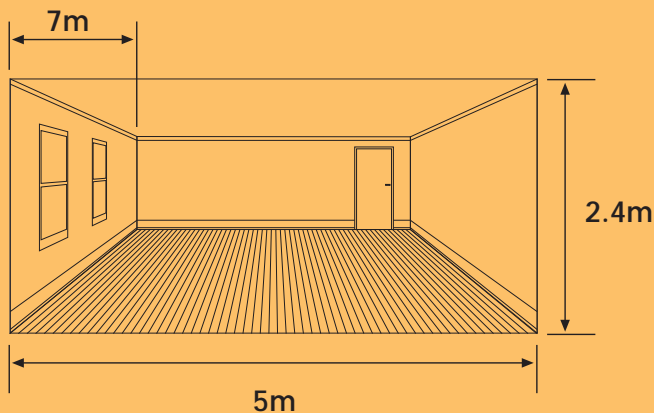

Multiplying these dimensions shows the room's total volume ( $7 \times 5 \times 2.4$ ) is  $84\text{m}^3$ .

Multiply  $84 \times 0.05 = 4.2$  (Always use 0.05)

This figure shows that under normal circumstances, you'll need a gas heater with a kilowatt output rating of **4.2 kW** for the room.

### Heating appliances

- Gas heating is clean, efficient and easy to use.
- Enjoy instant warmth without the hassles of chopping and storing firewood or coal.
- In-built fires can be fitted into existing fireplaces.
- Freestanding gas fires can be installed nearly anywhere, no hearth required.
- Wide range of modern appliances available to complement your décor.

Get OnGas and get all the warmth and cosiness you'll ever need without the smoke and mess of an open fire or the expense of some alternative heating methods.

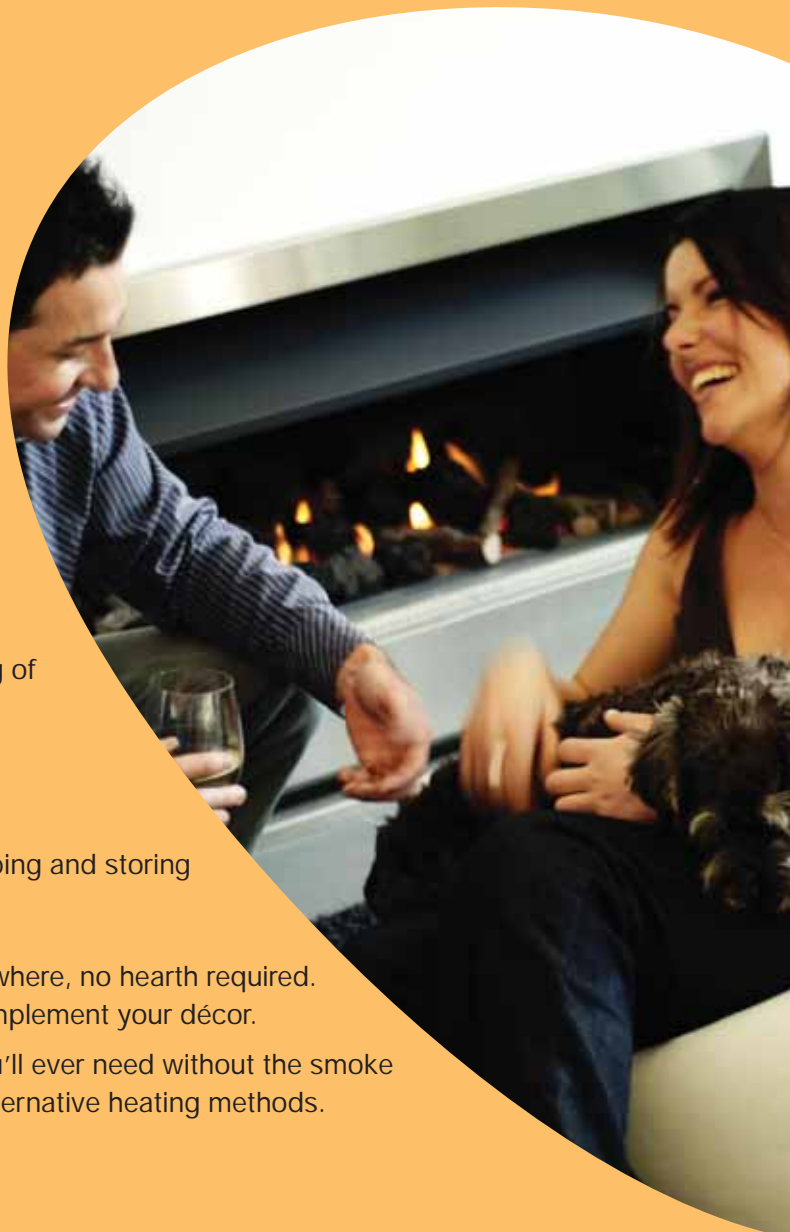

## Why hot water is easier with OnGas

Unlimited hot water any time of the day or night – that's the beauty of bath times with OnGas. You'll also be able to power through mountains of washing and still have an endless hot water supply for showers and baths, no matter how large your family or how many friends and relatives come to stay.

**A mains water pressure system** should be considered when having gas installed.

- Increased pressure reduces the effect of a change in temperature if a tap is turned on elsewhere in the house while you're in the shower.
- Baths, washing machines and dishwashers fill quicker, reducing your waiting time.
- Everyone in the house can enjoy strong, hot showers.

### With gas you can choose between two basic types of water heater

#### **A continuous flow gas hot water system**

- Reliable – never run out of hot water, as the water is heated as it flows to the tap.
- Economical – only uses gas when your hot water tap is turned on.
- Space saving – no cylinder means extra storage or other space options in your home.
- Precise – setting the water temperature means risk of burns is reduced.

#### **A gas hot water cylinder**

- Flexibility with positioning – can be installed inside or outside your home.
- Responsive and time saving – most gas cylinders will heat your water from cold in less than an hour.
- Numerous size options – choose the best model to suit your home.
- No electricity required – power cuts won't affect your hot water supply.



Heating your water with OnGas means you will have endless hot water for all your home needs, including a luxurious spa, hot tub or pool. You need never run out of hot water again.



## Why home cooking is easier with OnGas

If you love cooking, you'll love cooking with OnGas. With the vast array of designer-styled cooking appliances and the instant heat and precise control that gas delivers, it's easy to see why gas is the choice of chefs and home designers alike.

### Cooking Appliances

- Ultimate cooking control – cook your food exactly the way you like it.
- Succulent results – water vapour produced by gas keeps food moist.
- Many styles and configurations – find the one that suits your layout and style of cooking.

### Barbecues

- A huge range of models are available – choose one that suits your cooking style.
- Fixed models available – you can connect these to piped gas or a large bottled gas supply so you never have to worry about the gas running out at a crucial time.

If you're building or renovating a home, then upgrading to gas gives you the perfect opportunity to create a modern, designer kitchen with sleek appliances that make the most of the beauty of cooking with OnGas.



# Piped LPG

## How does it work?

OnGas piped LPG offers you all the benefits of a continuous gas supply. A specially engineered bulk vessel safely stores a large supply of LPG on site, and gas travels through underground pipes before passing through a meter located in an accessible position on your property.

OnGas will read your meter regularly and send you an account, much like your electricity supply. You just need to sit back and enjoy all the benefits gas provides.

### 4 simple steps to getting piped LPG

- 1. Call 0800 84 12 12** to arrange for the gas connection. OnGas will lay the new gas service pipe from the street to your house, and mount the gas meter in a suitable location, and set you up with an account.
- 2. Choose your appliances.** A great range of gas appliances are available from an approved OnGas retailer and we can put you in touch with one who can give advice on what is right for you.
- 3. Set up your account.** Your OnGas representative will open your account and send you a welcome pack. There are a range of payment options available, including telephone banking and direct debit.
- 4. Installation of appliances and cylinders.** We can put you in touch with a certified gasfitter who will install and run pipes from the meter to the various points around your home and install the appliances.

**The gas is On!** Your gasfitter will turn on the gas and ensure the installation is safe and meets all industry codes and standards. It is a legal requirement that a "Gasfitting Certification Certificate" is issued to you by your gasfitter on completion.



## Terms and conditions of piped LPG supply

### 1. Introduction

**1.1** These terms and conditions of supply govern the sale of gas by the Company to the Customer.

**1.2** Where the Customer comprises more than one person, each person is jointly and severally responsible for complying with this Agreement.

### 2. Fees and charges

**2.1** The Customer will be charged and has agreed to pay the fees and charges set out in the OnGas price list applying from time to time. Fees and charges are GST inclusive.

**2.2** The Company may alter the price it charges for supplying Gas at any time by giving a minimum of 2 weeks' notice to the Customer.

### 3. Payment

**3.1** The Customer will pay the total amount contained in any invoice sent to the Customer without deduction or set off of any kind on, or before, the 20th of the month following the date on which the Company issued that invoice. The Company may at any time require immediate payment from the Customer (without formal demand) if the Company in its discretion considers the Customer to be a credit risk.

**3.2** In some circumstances the Company may require a deposit to be paid by the Customer before the Company supplies gas. This deposit will be held against the non-payment of future invoices and will be used to clear any final invoice. Any credit will be refunded to the Customer by cheque on the termination of this Agreement.

**3.3** In the event the Customer has not paid an invoice to the Company by the due date the Customer must pay:

(a) Interest on all sums outstanding from the due date until full payment is made on a daily basis (at a rate calculated by adding 5% per annum to the overdraft rate payable by the Company to its banker at the time of and during such default); and

(b) All costs incurred by the Company in recovering payment from the Customer including without limitation all debt collector's fees or commissions, legal fees and disbursements and Company clerical costs.

**3.4** If the Customer does not pay an invoice then the Company may disconnect supply.

### 4. Delivery

**4.1** The Company has contracted with the Network Provider to provide Network Services for the delivery of gas to the Customer.

**4.2** The connection of the Customer to the Network and supply of gas to the Customer from the Installation to the Site is provided in accordance with the Network Service Agreement and is the sole responsibility of the Network Provider. The Customer agrees that the Network Provider is entitled to disconnect supply if the Customer does not grant the rights specified in this Agreement or the Customer's equipment does not meet the Network Provider's requirements.

**4.3** The supply of gas is subject to interruptions (for maintenance, emergencies and other causes) by the Network Provider in accordance with the Network Services Agreement. Please contact us if you wish to see the full details of the Network Services Agreement.

### 5. Metering

**5.1** The Company will provide or arrange for the provision of a Meter to measure gas supplied. The Customer agrees Meters will be read based on cubic meters supplied and converted to kilograms using a conversion factor based on average ambient temperatures, which is subject to change by the Company if necessary. The Network Provider has agreed to provide connection services in respect of Customers and to install Meters. The Customer agrees to make payment of invoices for Connection Fees directly to the Network Provider.

**5.2** The Customer agrees to allow the Network Provider to install an appropriate Meter on the Site and to provide a safe, secure and accessible location for the Meter. Meters will be read on a regular basis no less than every two months unless agreed otherwise.

**5.3** If the Customer thinks a Meter is faulty the Customer must contact the Company as soon as possible. The Customer must not attempt or allow any person other than the Company or the Network Provider to work on, inspect or interfere with a Meter. The Customer must use all care of a cautious and prudent owner to prevent damage to the Meter and take such action as the Company may reasonably require to ensure that the safety and integrity of the Meter at the Site is not threatened. Where the Customer fails to do so, the Customer must reimburse the Company or the Owner of the Meter for any loss or damage that occurs to a Meter.

### 6. Access to your site

**6.1** The Company's staff and contractors and those of the Network Provider are to have unobstructed access to the Site to read Meters from 7.30am until 7.00pm Monday to Saturday. The Company may

charge the Customer for making a special Meter reading if the Customer does not provide access during the above hours.

**6.2** Estimates of the amount of gas supplied will be made and invoices will be based on these where the Meter cannot be read because access cannot be gained to the customer's site.

**6.3** The Customer must also give the Company and the Network Provider safe and unobstructed access to its Site to perform work, maintenance and inspections necessary to ensure the continuity and safety of the supply of gas or to determine the amount of gas supplied or for any other related purpose.

### 7. Risk

**7.1** The risk of any loss, damage or deterioration of the gas will pass from the Network Provider to the Customer when the Gas is made available to the Customer at the Delivery Point by the Network Provider, in accordance with the Network Services Agreement.

### 8. Liability

**8.1** The Company will not be liable to the Customer or any other person for indirect or consequential loss or damage of any kind arising out of, or attributable to any breach by the Company of its obligations under any contract (including this Agreement), negligence on the part of the Company, or any act or omission by the Company, and for the purposes of these terms and conditions consequential loss will include (without limitation) loss of use of goods or services, loss of income or profits and loss or damage to persons or property.

**8.2** Regardless of the legal basis of any claim made by a Customer against the Company (including for breach of contract or negligence) the Company's liability under any such claim will be limited to the total of the previous 3 months invoices for gas supplied under the Gas Supply Contract.

**8.3** The Customer will indemnify the Company from any claim made by any third party in respect of any damage or loss to any third party arising from any misuse or unauthorised use of gas, Meter or associated equipment while in the possession of the Customer. The Customer must not remove any Meter or associated equipment from the Site without the consent in writing of the Company.

**8.4** The Company will not be liable to the Customer where the loss or damage suffered arises from an event or cause beyond the Company's control. An event or cause beyond the company's control includes, but is not limited to, acts of God, war, earthquake, lightning, storm or other similar event, faults in the Network and acts or omissions by the Network Company.

### 9. Gas supplied

**9.1** The Customer and the Company will comply with their respective obligations under the Gas Act 1992, the Gas Regulations 1993 (except as described in clause 5.1) and any gas codes of practice issued under the Gas Act 1992.

**9.2** Gas purchased must not be resold by the Customer and any unintended escape of gas must be reported by the Customer to the Company immediately.

### 10. Term and termination

**10.1** The Agreement may be terminated by either party by giving 2 weeks notice to the other or if any of the following occurs:

(a) Either party is in default under this Agreement and (if the breach is capable of remedy) has failed on receipt of seven days notice in writing from the non-defaulting party to remedy the default;

(b) The Customer has failed to pay an invoice for Gas supply.

**10.2** If the Customer does not give 2 weeks' notice to terminate the Agreement but vacates the Site, the Company will be entitled to retain any deposit it has received from the Customer.

**10.3** Upon termination the Customer must allow the Company or the Network Provider to enter the Site to reclaim the Meter and any associated equipment.

**10.4** If the Customer leaves the site without notice to OnGas, all gas used will continue to be the responsibility of the Customer and will continue to be charged to the Customer.

### 11. Privacy act

**11.1** The Customer agrees to provide all the information we reasonably require and grants us permission to use this information for the purposes of managing their account and for general marketing purposes. The Customer agrees that we may obtain any such information from relevant third parties. The Customer agrees to tell us immediately when any details change.

**11.2** The Customer agrees that we may make enquiries to credit reporting services about the Customer and that the Company may provide information to credit reporting services for their purposes, including listing on their systems, use in their credit reporting services, and supply to their customers. The Customer authorises credit reporting

services to provide the Company with such information as the Company may require.

**11.3** The Company may disclose the Customer's personal information to carry out the Company's responsibilities or enforce the Company's rights under this Agreement including for the purposes of credit reference checking.

**11.4** Other than as permitted by clauses 11.2 and 11.3, the Customer's personal information will be kept secure and held by us in accordance with the Privacy Act 1993 at 101 Carlton Gore Road, Newmarket, Auckland, New Zealand. Under the Privacy Act 1993, the Customer has rights to access and correct personal information that we hold. The Customer is able to correct or change the information collected at any time and as often as they require by calling us on 0800 84 12 12.

### 12. Events beyond the company's control

**12.1** The Company is not required to supply Gas to the Customer or to carry out any other obligations under this Agreement where it is not reasonably practical to do so because a circumstance or event has occurred which is beyond the Company's reasonable control and which prevents the Company from carrying out such responsibilities"

### 13. General

**13.1** All rights of the Company shall remain in force notwithstanding any delay or forbearance of enforcement and no waiver of any of these terms and conditions will apply unless such waiver has been expressly agreed to in writing by the Company.

**13.2** This Agreement constitutes the entire agreement between the Company and the Customer in respect of its subject matter and supersedes all prior negotiations, representations and agreements between the Customer and the Company.

**13.3** From time to time the Company may vary the terms and conditions (including fees and charges) or the form of this Agreement on giving the Customer 2 weeks' notice of the variation.

**13.4** In the event the Consumer Guarantees Act 1993 applies to this Agreement then the Act expressly overrides any of these terms and conditions that are inconsistent with it.

**13.5** This Agreement is not assignable by the Customer to any third party.

**13.6** This Agreement is intended to be for the benefit of and shall be enforceable by the Network Provider for the purposes of the Contracts (Privity) Act 1982.

### 14. Notices

**14.1** Invoices and notices will be delivered to the Site or mailed or sent to the last known physical or postal address or facsimile number.

### 15. Definitions

"**Agreement**" means this agreement (including these terms and conditions) as amended from time to time.

"**Company**" refers to OnGas Ltd.

"**Connection Fee**" means the fee charged by the Network Provider or its agent, covering its performance of connection and installation services.

"**Customer**" means the residential Customer identified in the Gas Supply Contract.

"**Delivery Point**" means the Customer's point of supply for gas, being the point at which the network connects to a customer's equipment, which shall be at or near the Meter.

"**GST**" means Goods and Services Tax payable pursuant to the Goods and Services Act 1985.

"**Installation**" means the storage tank and ancillary equipment owned by the Company or Network provider and used for the storage of gas.

"**Gas**" means liquefied petroleum gas which complies with NZ Standard 5435 (or as subsequently modified).

"**Meter**" means a gas meter (including all protective covers, valves and associated equipment), which is used to measure the supply of gas to the Customer.

"**Network**" means the gas distribution system comprising pipes, valves, fittings, meters and plant used for the delivery of gas from the installation to the customer's site.

"**Network Provider**" means the company or organisation that owns the Network, and its agents.

"**Network Services**" means the services to be provided under the Network Services Agreement between the Network Provider and the Company in respect of the receipt and storage of Gas in the Installation, the installation and commissioning and maintenance of Meters for Customers and the connection of Customers to the Network and the distribution of gas from the Installation to Customers by means of the Network.

"**Network Services Agreement**" means the master and operating license agreements between the Network Provider and the Company for the provision of Network Services.

"**Site**" means the site address referred to in this Agreement, being the address of the Customer and location of the Delivery Point.

## See the difference in your bills

Gas is the economical choice. You'll enjoy the benefits of longer showers, warmer rooms and instantly responsive cooking, yet you may still save money on your energy bills.

This is because gas is more efficient than other energy fuels. Also, gas appliances are usually cheaper to operate and maintain in the long term.

## To get OnGas

0800 84 12 12

enquiries@ongas.co.nz

### About OnGas

OnGas is the gas brand for Vector Limited. Vector is New Zealand's leading multi-network infrastructure company. Our group owns and manages a range of energy, technology and service businesses and assets which touch more than one million New Zealand homes and businesses. You can find out more about Vector at [www.vector.co.nz](http://www.vector.co.nz)

OnGas is a future proof product. Here's why:



#### Resource Responsibility

Gas is the environmentally friendly fuel. Of all the fossil fuels available, gas creates the least greenhouse gas emissions. It is highly flammable, burns almost completely and is considered a clean fuel as it does not produce any ash, dust or smoke. When gas burns efficiently in the air, it produces energy, water vapour and carbon dioxide. Environmental concerns are also addressed in the design of modern gas appliances which feature sophisticated burner systems, and produce fewer emissions.



#### Energy Efficiency

Gas is nearly three times more efficient when used as a direct fuel rather than as a source of fuel to generate electricity, contributing to the improvement of New Zealand's energy efficiency. An example of the efficiency of using natural gas as a direct energy source is the difference in gas consumption to boil water using an electric kettle compared to a kettle on a gas hob. The electric kettle uses 2.8 times more gas than a kettle boiled using a gas hob.



#### Health and Safety

Gas is very safe. The built-in safety features of today's modern appliances and advances in technology ensure that gas is a safe energy option, whether piped or supplied in bottles. A smell has been added to the gas supply for easy detection if a leak occurs. There are certain room size restrictions on whether appliances need to be flued.



#### Space Management

Modern gas appliances are sleek and contemporary, allowing more open space in living areas. Continuous flow water heaters can be placed on the outside of the home so there is no need for an indoor water cylinder taking up valuable space. This can be used for extra storage or other space requirements.



Printed on paper from responsibly-managed forests. Paper certified by the Forest Stewardship Council complies with rigorous standards concerned with ecology, economy & society. To read more about FSC paper visit <http://www.fsc.org>

Ver 1.4 (10/2008)

© Copyright 2008 Vector Limited. "OnGas" is a registered trade mark of Vector Limited. All rights reserved.



[www.ongas.co.nz](http://www.ongas.co.nz)

## NEW BUILD HOME OR NEW CONNECTION (FOR A NEW GAS CONNECTION TO PROPERTY)

### 1 SITE DETAILS

Lot No. of site:

Address of site:

Subdivision name:

Town/City:

### 2 NEW HOME/SITE CONNECTION DETAILS

*This section can be completed by Builder/Project Manager arranging Connection/Meter Installation.*

Building Company:

Contact Person for Meter Installation (e.g. Project Manager):

Mobile:  Fax:

Email:

Postal Address:

Estimated Dwelling Completion Date:   
(1 Week Advance Notice Required for Connection)

Connection — Where is the Meter to be Located (tick one):

Standard Installation (\$450 + GST) is at boundary fence line at services connection point. Pipes run to boundary of section nearest to main – no greater than 2 meters in from front of property.

Other Installation – separate quote required from OnGas.

Connection Cost to be paid by (tick one):

Gas Account Holder  Builder

Printed Name:

Signature:

### 3 NEW GAS ACCOUNT HOLDER DETAILS

*This section to be completed/signed by new gas account holder.*

Title (tick one):  Miss  Ms  Mrs  Mr

Name:

Current Contact Address:

Mobile:  Work:

Email:

Gas Used For (tick one):  Hot Water  Heating  
 Central Heating  Cooking

Signature:

NOTE: From the time the meter is commissioned, the account holder is responsible for gas used and will be charged. Please refer to number "2. Fees and Charges" in the OnGas Terms & Conditions for Piped LPG Supply. By signing this application you acknowledge you've read, understood and agreed to the OnGas Terms & Conditions.

## EXISTING HOME (TO RE-CONNECT TO GAS/SET UP AN ACCOUNT)

A CONNECTION FEE WILL APPLY. An OnGas authorised gasfitter is required to recommission the gas supply.

### 1 SUPPLY DETAILS

Date for gas to be turned on:

Gas Used For (tick one):  Hot Water  Heating  
 Central Heating  Cooking

Gas Meter No. (if known):

### 2 CUSTOMER DETAILS

*This section to be completed/signed by the customer.*

Title (tick one):  Miss  Ms  Mrs  Mr

Name:

Address for Gas Connection:

Mobile:  Work:

Email:

Billing & Correspondence Address (if different from above):

Are you the:  Property Owner  Tenant

If Tenant please state Landlord's details:

Name:

Mobile:  Work:

Email:

Printed Name:

Signature:

By signing this application you acknowledge you've read, understood and agreed to the OnGas Terms & Conditions.

## REMEMBER!

If moving permanently from this property, contact OnGas with your final meter reading to avoid ongoing gas use charges.

### Easy Form Return:

- 1 A FREEPOST envelope is provided by folding this form into 3 – simply adhere the edges to make an envelope and POST.
- 2 FREEFAX to 0800 84 13 13



P 0800 84 12 12  
F 0800 84 13 13  
www.ongas.co.nz

Fold Here

Freepost Authority Number 138067



ONGAS LTD  
PO BOX 486  
WAIKATO MAIL CENTRE  
HAMILTON 3240

Fold Here

Seal Here